



## Owner's Manual

# BP-15 SUPER Shotblasting Machine w/ BP-9-54 Dust Collector



**BLASTPRO MANUFACTURING, INC. ~ WARRANTY & REGISTRATION CARD**  
**ONE YEAR LIMITED WARRANTY**  
(1-877-495-6464)

**A COPY OF THE WARRANTY CARD ON THE FOLLOWING PAGE, TOGETHER WITH PROOF OF PAYMENT, MUST BE SUBMITTED WITH ANY SERVICE REQUEST. THIS WARRANTY CARD MUST BE RETURNED TO: BLASTPRO MANUFACTURING, INC., 6021 MELROSE LANE, OKLAHOMA CITY, OK 73127, WITHIN TEN (10) DAYS OF ACQUIRING BLASTPRO PRODUCTS IN ORDER TO QUALIFY FOR THE ONE YEAR LIMITED WARRANTY CONTAINED IN THE SALES AGREEMENT.**

---

BlastPro provides as a limited warranty to Original Purchasers of BlastPro equipment, purchased within and situated within the United States of America, who notify BlastPro in writing through completion of the BlastPro Equipment Warranty Card within ten (10) days of acquiring BlastPro Equipment, the following limited warranty.

Subject to the exclusions, limitations and conditions stated above and below, BlastPro will warrant its products against defects in materials and workmanship, provided the Original Purchaser uses such equipment under normal and proper use, for a period of one year or 1,000 hours, whichever occurs first, from the date of delivery to the Original Purchaser.

During the applicable limited warranty period and subject to the exclusions, limitations and conditions contained herein, BlastPro shall, within a reasonable period of time, repair or replace, at its option, any defective components of the equipment. The limited warranty does not cover wear parts, including but not limited to, tires, magnets, seals, casters, liners, wear plates, bearings, cages, blast wheels, blades, belts, electrical wiring components and items of a similar nature.

This limited warranty does not cover damage to BlastPro equipment caused by any of the following: the use of the equipment for purposes other than which the equipment was designed and intended, all external causes such as (without limitation) acts of God, accidents, dropping, collision, fire, water damage, freezing, striking other objects, misuse or otherwise using the equipment contrary to the instructions and warnings contained in the User Manual; altering or modifying BlastPro equipment or accessories; exposure to environmental conditions beyond reasonable limits and the limits stated in the equipment manual; failure to properly maintain and service the equipment; damage caused by the use of any non-BlastPro parts or attachments on the equipment.

To obtain repair or replacement under this limited warranty, the Original Purchaser must contact BlastPro at 1-877-495-6464. The Original Purchaser must be prepared to describe any alleged problem, as well as provide proof of purchase and proof of date of delivery and return of the Equipment Warranty Card. Written authorization from BlastPro must be obtained prior to any BlastPro equipment being returned to BlastPro.

Once BlastPro provides the Original Purchaser with a written authorization, then the Original Purchaser shall deliver the equipment as instructed by BlastPro. The Original Purchaser shall pay the cost of shipping and shall also bear any risk of loss during shipping. Providing the BlastPro equipment is defective and the limited warranty applies, BlastPro shall, within a reasonable period of time, repair or replace any defective components. The Original Purchaser shall be responsible for picking up the repaired equipment or may arrange for shipment at Original Purchaser's expense.

BlastPro's repair or replacement of any defective parts on the equipment does not extend the term of this limited warranty, which shall expire on expiration of the period of one year from the date of Original delivery, subject to the further terms of this warranty.

---

**THIS LIMITED WARRANTY IS THE ONLY WARRANTY APPLICABLE TO BLASTPRO EQUIPMENT. BLASTPRO DISCLAIMS ALL OTHER WARRANTIES, EXPRESS OR IMPLIED, INCLUDING IMPLIED WARRANTIES OF MERCHANTABILITY OR FITNESS FOR A PARTICULAR PURPOSE, OTHER THAN THOSE WARRANTIES IMPLIED AND INCAPABLE OF EXCLUSION, RESTRICTION OR MODIFICATION UNDER APPLICABLE LAW. ANY SUCH IMPLIED WARRANTIES WHICH MAY BE REQUIRED BY LAW AND ARE NOT DISCLAIMED HEREBY, ARE LIMITED TO THE EXTENT ALLOWED BY LAW TO THE APPLICABLE PERIOD OF THIS IMPLIED WARRANTY OR TO THE APPLICABLE TIME PERIOD PROVIDED BY THE APPLICABLE STATE LAW, WHICHEVER PERIOD IS SHORTER.**

**UNDER NO CIRCUMSTANCES SHALL BLASTPRO BE LIABLE TO THE ORIGINAL PURCHASER OR ANY OTHER PERSON FOR ANY DIRECT, INDIRECT OR CONSEQUENTIAL DAMAGES RESULTING FROM THE USE OR MISUSE OF THE EQUIPMENT OR ARISING OUT OF ANY BREACH OF ANY WARRANTY OR FOR ANY SPECIAL OR CONSEQUENTIAL DAMAGES OF ANY CHARACTER, INCLUDING WITHOUT LIMITATION, DAMAGES FOR ANY LOSS OF GOODWILL, WORK STOPPAGE OR ANY AND ALL OTHER COMMERCIAL DAMAGES OR LOSSES.**

**NO CHANGE TO OR ADDITIONAL WARRANTY, NO MATTER BY WHOM MADE OR WHEN MADE, SHALL APPLY TO ANY EQUIPMENT SOLD BY BLASTPRO.**

**BlastPro Warranty Registration Card**

**NOTICE!**

To ensure the proper warranty coverage is extended to the owner of this machine, fill out the attached card **COMPLETELY** and **ACCURATELY** and return to BlasPro Mfg.

Keep this top portion for your records

**USER'S REFERENCE INFORMATION**

<b>Delivery Date</b> _____	<b>Machine Model No.</b> _____
<b>Delivering Distributors Name</b>	<b>Machine Serial No.</b> _____
<b>and Address</b> _____	<b>Modifications</b> _____
_____	_____
_____	_____
_____	_____
_____	_____

CUT HERE

**WARRANTY REGISTRATION CARD**

**IMPORTANT!** To ensure that your BlastPro machine is covered under warranty, please fill in the following information and mail it to BlastPro Manufacturing, Inc. 6021 Melrose Lane, Oklahoma City, OK 73127, or Fax to 405-495-1331

(All boxes must be checked or date filled in)

Operating Manual Received  Training Scheduled \_\_\_\_\_ Training Complete

(Please Print)

**Company** \_\_\_\_\_  
**Address** \_\_\_\_\_  
**City** \_\_\_\_\_ **State** \_\_\_\_\_ **Zip** \_\_\_\_\_  
**Phone Number** \_\_\_\_\_  
**Contact Person** \_\_\_\_\_  
**Purchase Date** \_\_\_\_\_ **Delivery Date** \_\_\_\_\_  
**Machine Model No.** \_\_\_\_\_  
**Distributor Name** \_\_\_\_\_

# BP-15 SUPER Table of Contents

<b>FORWARD</b> .....	<b>2</b>
<b>INTRODUCTION</b> .....	<b>3</b>
SPECIFICATIONS.....	3
<b>SAFETY INSTRUCTIONS</b> .....	<b>4</b>
SAFETY — GENERAL.....	4
SAFETY — SITE ASSESSMENT .....	4
SAFETY — START UP .....	6
SAFETY — OPERATION PROCEDURES.....	8
SAFETY — SHUT DOWN PROCEDURES .....	8
SAFETY — MAINTENANCE PROCEDURES .....	9
<b>OPERATING INSTRUCTIONS</b> .....	<b>10</b>
SETTING THE BLAST PATTERN.....	10
<i>Proper Control Cage Setting Drawing</i> .....	11
<b>TRANSPORTATION</b> .....	<b>12</b>
<b>WEAR PARTS</b> .....	<b>12</b>
<b>MAINTENANCE</b> .....	<b>13</b>
BLAST WHEEL REMOVAL AND INSTALLATION .....	13
GENERAL MAINTENANCE POINTS.....	14
<b>PARTS LISTS</b> .....	<b>15</b>
LINERS AND SEALS .....	15
FRONT END ASSEMBLY .....	16
MAJOR WELDMENTS .....	18
BACK END ASSEMBLY .....	19
BLAST WHEEL ASSEMBLY .....	20
GENERAL ASSEMBLY.....	22
<b>INSTALLATION INSTRUCTIONS FOR D65 SERIES PHASE MONITORING RELAY</b> .....	<b>24</b>
<b>SHOTBLASTING PROBLEMS &amp; POSSIBLE SOLUTIONS</b> .....	<b>26</b>

## **Forward**

Thank you for your purchase of a shotblasting machine from BlastPro Manufacturing, Inc. We feel that you have purchased the highest quality shotblasting equipment on the market today.

This manual has been prepared to give the operator a general understanding of the machine. It is not intended to be an all encompassing document which addresses every situation which may be encountered when operating the machine. **BEFORE OPERATING, MAINTAINING, OR SERVICING THE EQUIPMENT, THIS MANUAL SHOULD BE READ BY THE INDIVIDUALS RESPONSIBLE FOR OPERATION, MAINTENANCE, OR SERVICE OF THE EQUIPMENT.**

The individuals responsible for operating, maintaining, and servicing the equipment should thoroughly understand and follow all safety precautions listed on the equipment and the safety instructions listed in this manual. As with any piece of construction equipment, serious damage to the equipment and serious injury can occur if the safety instructions and safety warnings are not followed.

If you have any questions or problems regarding the operation of the equipment, then please call:

BlastPro Manufacturing, Inc.  
6021 Melrose Lane  
Oklahoma City, OK 73127  
Toll free: 877-495-6464  
Phone: 405-491-6464  
Fax: 405-495-4994  
Website: [www.BlastProMfg.com](http://www.BlastProMfg.com)

## Introduction

The BP-15 SUPER operates on dual voltage, 230/460 volts, 208 3-phase, and offers a 15” blast pattern. The newly designed blast wheel and the advanced air wash system, along with the high quality control box and electrical components that are engineered and constructed by a UL certified electrical contractor result in longer lasting wear parts. The BP-15 SUPER is solid with the BP-9-54 dust collector to keep work areas clean and dust-free. The BP-15 SUPER’s versatility makes it suitable for use on medium to large projects, including warehouse floors, parking garages, industrial plants, bridges, and highways. The BP-15 SUPER has a travel speed of 0-100 feet per minute and production capacity from 350 – 1,950 square feet per hour. Shot size: S-280 to S-460. Wear parts are interchangeable with BLASTRAC<sup>®</sup> parts.

The mechanics of the BP-15 SUPER are fairly simple. When the shot lever is squeezed, a cable connected to the shot lever opens the shot valve which subsequently allows shot from the shot hopper to be released. The shot then moves through the shot valve, down the feed spout, and into the blast wheel which sits in a control cage. Simultaneously, a 15 horsepower 3-phase motor is spinning the blast wheel at a very high rate of speed. This spinning blast wheel then acts to throw the shot through an opening in the control cage and down onto to the concrete surface that is being cleaned. Due to the high rate of speed at which the shot is traveling, it acts to fracture the concrete surface which consequently produces concrete dust. After hitting the concrete surface, the shot rebounds off of the surface and, through a combination of the rebound effect and the use of a vacuum, the shot and the concrete dust then move through the blast housing. Because shot is heavier than concrete dust, gravitational force separates the shot and the concrete dust. The shot is then sent back into the shot hopper where it is continuously recycled by the machine. As for the concrete dust, it is sucked into a duct hose which travels from the blast housing to the dust collector. After traveling through the duct hose, the concrete dust is deposited in the dust collector’s dust bin.

## Specifications

<b>Model Number:</b>	BP-15 SUPER	<b>Minimum Generator:</b>	60 kW
<b>Production Capacity:</b>	1,950 sq. ft./hr.	<b>Dimensions (L x W x H):</b>	72” x 23” x 41”
<b>Blast Pattern:</b>	15”	<b>Weight:</b>	847 lbs.
<b>Travel Speed:</b>	0-90 ft/min.	<b>Power Cord Included:</b>	55 ft.
<b>Blast Motor:</b>	20 hp	<b>Seals:</b>	Magnetic
<b>Voltage:</b>	230 / 460 V, 60 Hz	<b>Distance to Edge:</b>	2.5”
<b>Amperage:</b>	70 / 34 Amp	<b>Dust Collector:</b>	BP 9-54



# DANGER



**Respirable crystalline silica**  
**May cause cancer**  
**Causes damage to lungs**



**Insure compliance with**  
**OSHA 29 CFR §1926.1153**

## **Safety Instructions**

ALL OPERATORS AND MAINTENANCE PERSONNEL SHOULD READ THIS SECTION CAREFULLY BEFORE OPERATING OR MAINTAINING THIS EQUIPMENT. THESE SAFETY INSTRUCTIONS ARE NOT MEANT TO REPRESENT AN ALL-INCLUSIVE LIST OF INSTANCES WHICH COULD OCCUR WHEN OPERATING THIS EQUIPMENT. FOR, AS WITH ANY PIECE OF CONSTRUCTION EQUIPMENT, SERIOUS INJURY CAN OCCUR IF PROPER SAFETY PROCEDURES ARE NOT DILIGENTLY FOLLOWED. ALL SAFETY AND WARNING LABELS POSTED ON THE MACHINE MUST BE FOLLOWED AS WELL AS THE SAFETY PROGRAM INSTITUTED BY YOUR COMPANY. THERE IS NO SUBSTITUTE FOR SOUND JUDGEMENT IN THE OPERATION AND MAINTENANCE OF THIS EQUIPMENT. IN CASES WHERE OPERATING PERSONNEL HAVE INSUFFICIENT KNOWLEDGE OR UNDERSTANDING OF THE ENGLISH LANGUAGE, PROPER TRANSLATED TRAINING MUST BE COMPLETED BEFORE USE OF THIS EQUIPMENT CAN TAKE PLACE.

**Note:** This manual must be kept with the machine at all times so as to allow the operator easy access to its vital information.

### **Safety — General**

The United States Department of Labor's Occupational Safety & Health Administration (OSHA) provides statutory requirements, standards, and regulations relating to the use of portable tools on construction sites. These statutory requirements, standards, and regulations are posted on the OSHA website at [www.osha.gov](http://www.osha.gov). The operator and maintenance personnel should understand and follow these statutory requirements, standards, and regulations.

### **Safety — Site Assessment**

Before starting blasting operations, a site assessment must be performed. During the site assessment verify the following:

- Work area is flat, clean, and dry, free of debris, frost-free, and has no flammable liquids nearby. Also, make sure that the machine will be able to clear all obstructions. **NEVER BLAST A WET SURFACE! NEVER ALLOW PERSONNEL, ELECTRICAL CORDS, OR CONNECTIONS TO COME INTO CONTACT WITH ANY TYPE OF MOISTURE!**
- **NEVER BLAST OVER BOLTS, NUTS, SCREWS, NAILS, OTHER DEBRIS, OR OPENINGS IN THE BLASTING SURFACE AS THIS MAY RESULT IN SIGNIFICANT DAMAGE TO THE MACHINE AND SERIOUS INJURY TO THE OPERATOR!**
- If using a generator, then proper safety precautions have been undertaken in order to help reduce the risk of carbon monoxide poisoning. Making certain that the work area is well ventilated is extremely important. For further information, refer to the owner's manual of your generator.



- Each worker has a carbon monoxide monitor on their persons. These carbon monoxide monitors should be calibrated, in working order, and should be equipped with audible alarms that will warn workers if carbon monoxide levels become too high. **IF CARBON MONOXIDE LEVELS EXCEED 35 PARTS PER MILLION, ALL WORK MUST CEASE IMMEDIATELY! THIS REPRESENTS A POTENTIALLY DEADLY SITUATION WHICH NECESSITATES AN IMMEDIATE SHUTDOWN!**
- All workers have received training on the dangers of overexposure to carbon monoxide. Staff members must also be able to identify all of the signs and the symptoms associated with carbon monoxide poisoning. This training should ensure that work would stop immediately and emergency medical personnel would be notified promptly if one or more workers exhibited or complained of any of the common signs and symptoms associated with carbon monoxide overexposure, including: headache, nausea, weakness, dizziness, lethargy, visual disturbances, changes in personality, and/or loss of consciousness.
- **SURFACE HAS BEEN THOROUGHLY INSPECTED. SOME FLOOR OR DECK SURFACES MAY BE COATED WITH OR CONTAMINATED BY DANGEROUS MATERIALS SUCH AS PCBs, LEAD, ASBESTOS, PESTICIDES, SOLVENTS, CLEANING FLUIDS, AND/OR OTHER HARMFUL CHEMICALS. THE DUST PRODUCED FROM SHOTBLASTING SUCH SURFACES CAN CREATE A SERIOUS HEALTH THREAT TO THOSE WHO INHALE OR COME INTO CONTACT WITH THE DUST. AS A RESULT, THE WORK AREA MUST BE CHECKED FOR THESE MATERIALS BEFORE WORK CAN BEGIN. BLASTPRO MANUFACTURING, INC. DOES NOT WARRANT ITS EQUIPMENT TO BE SUITABLE FOR, OR APPROVED FOR, REMOVING DANGEROUS MATERIALS. IT IS THEREFORE THE RESPONSIBILITY OF THE CONTRACTOR TO AFFIRM THE SAFETY OF THE WORK AREA AND THE EQUIPMENT WITH THE PROPER AUTHORITIES. IT IS ALSO THE RESPONSIBILITY OF THE CONTRACTOR TO WARN ALL STAFF MEMBERS OF ALL POTENTIAL SHORT-TERM AND LONG-TERM HEALTH RISKS ASSOCIATED WITH INHALING AND COMING INTO CONTACT WITH DANGEROUS MATERIALS. THE CONTRACTOR IS RESPONSIBLE, FURTHERMORE, FOR PROTECTING ALL WORKERS FROM BEING EXPOSED TO DANGEROUS MATERIALS. SO, BECAUSE THE BP-15 SUPER SHOTBLASTING MACHINE HAS NOT BEEN DESIGNED TO REMOVE, CLEAN, PROFILE, OR ALTER ANY SURFACE COATED WITH OR OTHERWISE CONTAMINATED BY DANGEROUS MATERIALS, BLASTPRO MANUFACTURING, INC. EXPRESSLY DISCLAIMS ANY LIABILITY FOR INJURY, ILLNESS, DEATH, OR DAMAGE THAT MIGHT OCCUR OR RESULT FROM SUCH IMPROPER USE.**
- Operator and any other personnel in the work area are wearing safety glasses with side shields, dust masks, ear plugs, hard hats, steel-toed work boots, long sleeved shirts, tight fitting clothing, and gloves. It is also imperative for staff to tie back long hair and to remove all jewelry.
- Work area has been blocked off to pedestrians, unprotected personnel, and untrained personnel. In the event pedestrians, unprotected personnel, or untrained personnel enter the work area, blasting operations are to be stopped immediately.

- Fire extinguishers are nearby. Also, take note of the location and the contact information of fire departments close to the work site.
- Belt guards are in working order and are present on the machine at all times.
- All glass and equipment, including vehicles, are protected from steel shot. This can be done by loosely hanging a sheet of visqueen or other protective material in front of the glass or equipment in a curtain-like fashion. The importance of protecting glass and equipment from steel shot cannot be overemphasized.
- All floors drains have been plugged or covered so as to prevent steel shot from falling into the drains.
- This equipment is only being used for commercial purposes. This equipment is only to be operated by professional, trained, and competent operators.
- The operator is aware of his surroundings and will use common sense. **THE OPERATOR IS NOT TO OPERATE THE EQUIPMENT IF HE IS TIRED, DISTRACTED, OR UNDER THE INFLUENCE OF DRUGS, ALCOHOL, OR MEDICATIONS THAT DECREASE AWARENESS!**

### **Safety — Start Up**

After performing the site assessment safety procedures listed above, bring the BP-15 SUPER and the dust collector to the work area and perform the following procedures:

- Verify that personnel are competent and that they have read and understood the safety information in this manual. Staff must also be familiar with how to operate the machine and with all of its components. Make certain that all personnel follow all safety instructions and programs required by their company and by the worksite.
- Make certain that all belt guards are in working order and are present on the machine where needed.
- Verify that all of the machine's parts are assembled safely and correctly.  
**Note: It is recommended to have original spare parts and wear parts on hand. It is imperative that the machine receive special attention and regular maintenance in order to function properly and to operate safely.**
- Inspect all electrical cords on the BP-15 SUPER for damage, tears, or other signs of wear. If electrical cords are damaged, then do not attempt to perform blasting operations until cords have been repaired or replaced.
- Inspect the exhaust hose for damage. If exhaust hose is damaged, then do not perform blasting operations until the hose has been repaired or replaced.
- Inspect the dust collector. Verify that the dust bin is empty, filters are clean and clear of debris, and motors and fans are in working order.  
**Note: The dust bin must be emptied whenever it becomes full. Failure to empty the dust bin could result in serious damage to the machine and/or serious injury to the operator.**
- Inspect the duct hose leading from the BP-15 SUPER to the dust collector. Make sure hose is free of debris, hose is not cracked and holes do not exist. If necessary replace hose.
- Make certain that all screws and other fasteners are tight.

- Check the shot storage hopper, the feed spout, and the blast wheel parts for foreign bodies and remove them if present.
- Check the blast wheel blades, control cage, liners, and magnets for damages and wear. Wear grooves are acceptable until 50% of blade thickness has been worn away. When blade thickness has been worn away by more than 50%, replace all blades as a set.
- Check the front, side, and rear seal system and brush seals for excessive wear.
- Check the tightness of the hose connections and the condition of the hose to the filter.
- Check the electrical connections for dirt and foreign body deposits.
- Verify that the electrical motors are free of dirt and other contaminants.
- Check the level of shot in the storage hopper. Refill hopper if necessary.
- Verify that the main power cable and the dust hose are free of damage. Replace or repair all damaged parts before putting the machine into operation.
- Connect the blast cleaning machine and the filter unit with the dust hose. Use hose clamps at the connections.
- Connect the supply cable of the blast cleaning machine with filter unit. Connect the electrical cable of the filter unit with the site supply.
- Make certain that the side seals are positioned correctly in the side seal boxes.
- Check that the filter dust container has been emptied.
- Always blast in a straight line away from the dust collector. Blasting in a straight line will produce the most uniform results. **NEVER RUN OVER ANYTHING WITH THE BP-15 SUPER! RUNNING OVER AN EXTENSION CORD, AIR LINES, REBAR EXPANSION JOINTS, OPENINGS IN FLOOR, DRAINS, ETC. WITH THE BP-15 SUPER CAN RESULT IN SERIOUS INJURY TO THE OPERATOR AND/OR DAMAGE TO THE EQUIPMENT!**
- Make certain to keep hands away from all moving parts once the machine is in operation.
- Make certain to never stand next to the blast housing while the BP-15 SUPER is in operation as blade failure could result in serious injury.
- Make certain that the shot hopper door is closed while the machine is in operation as the BP-15 SUPER throws shot which could present a serious danger if the shot hopper door is not properly closed.
- Make certain that the blast seals of the BP-15 SUPER are not worn out. As these seals provide the suction that is required by the machine, they will become dislodged if they become worn out. This will then result in shot being discharged from the machine. It is consequently recommended that the operator make absolutely certain that the blast seals are in good working condition before putting the BP-15 SUPER into operation.
- In the unlikely event of a failure, turn the ignition key to the OFF position.

**Note: If the BP-15 SUPER shotblasting machine is operated using a generator as the power source, the generator must be operated in accordance with the current VDE directives (this applies to the protective earth conductor in particular) in order to ensure that all safety devices are functioning and to eliminate possible damage to electrical components.**

## Safety — Operation Procedures

When operating the BP-15 SUPER, perform the following safety procedures:

- **SUPPORT PERSONNEL MUST KEEP A SAFE DISTANCE FROM THE MACHINE WHILE IT IS IN OPERATION! DO NOT STAND IN FRONT OF THE MACHINE WHILE IT IS IN OPERATION!**
- Since the speed of the machine determines the depth of its cut, it is advised that the operator run a test pattern. Failure to run a test pattern could result in the machine gouging the floor.
- The blast pattern needs to be inspected by the operator at least every ten feet as variation in concrete means that the concrete or the coated surface may be softer in some areas than it is in others.
- Whenever the dust collector becomes full, it must be emptied. Failure to empty the dust collector could result in the machine losing its suction to the floor. If this happens, then all of the shot will fall out of the shot hopper.
- Never switch off or remove the exhaust and ventilation devices when the machine is in operation.
- **A SECOND PERSON MUST BE PRESENT SO AS TO PULL OUT THE MACHINE'S PLUG IN AN EMERGENCY! THE WORK AREA MUST THEN BE SEALED OFF USING A RED AND WHITE SAFETY CHAIN AND A DANGER SIGN! USE A TOOL THAT IS INSULATED AGAINST VOLTAGES!**
- **IF AN ERROR OCCURS WHILE THE MACHINE IS IN OPERATION, IT MUST BE SHUT DOWN IMMEDIATELY! THE CAUSE OF THE ERROR MUST BE ESTABLISHED IMMEDIATELY!**
- **IF CABLES BECOME LOOSE OR SCORCHED, THE MACHINE MUST BE SHUT DOWN IMMEDIATELY!**

## Safety — Shut Down Procedures

When shutting down the BP-15 SUPER, always perform the following safety procedures:

- Shut off the shot supply by pulling the shot valve handle backward to the off position.
- Advance the machine until you are sure that no deep holes are being blasted into the surface.
- Turn off the breakers to the BP-15 SUPER and to the dust collector.
- Turn switch on the BP-15 SUPER and dust collector to the OFF position.
- Empty dust from the dust collector. **WHEN REMOVING DUST FROM DUST COLLECTOR, ALWAYS WEAR A PARTICLE MASK. CONCRETE DUST MAY CONTAIN PARTICLES WHICH ARE EXTREMELY HAZARDOUS! THESE PARTICLES SHOULD NEVER BE INHALED!**
- Empty all shot from the shot hopper on the BP-15 SUPER. Shot should never be left in BP-15 SUPER after work is performed. Never move or transport BP-15 SUPER with shot in the shot hopper as this may result in damage to the equipment.

- **AFTER COMPLETING WORK, CLEAN ALL STRAY SHOT FROM WORK AREA. SHOT CAN BE CLEANED WITH A MAGNETIC BROOM OR WITH A SHOP VACUUM. NEVER LEAVE STRAY SHOT IN WORK AREA AS SHOT REPRESENTS A SLIP AND FALL HAZARD! STEPPING AND FALLING ON STEEL SHOT CAN RESULT IN SERIOUS INJURY OR EVEN DEATH!**

### **Safety — Maintenance Procedures**

When performing maintenance on the BP-15 SUPER, make certain that the following safety procedures are followed:

- Verify that the BP-15 SUPER and the dust collector are not in operation. Attempting to perform maintenance operations on the BP-15 SUPER or the dust collector while they are in operation could lead to serious injury or death.
- Verify that all moving parts on the BP-15 SUPER have completely stopped moving.
- Make certain that all moveable parts have been secured so that accidental movement of the BP-15 SUPER will not result in these parts moving.
- Verify that the BP-15 SUPER and the dust collector are on a level and stable surface.
- Make certain that the BP-15 SUPER is in the Safety off position (valve is closed, blast machine is switched off, dust collector is switched off, all drives are at a standstill, and main plug has been pulled).
- Make certain maintenance personnel are wearing lint-free cleaning cloths.
- If repairing the underside of the BP-15 SUPER, then be certain to use jack stands. Never work under equipment that is not properly blocked.
- All repairs to electrical components, including wiring, should be performed by a licensed electrician.
- When performing electrical servicing work, make certain that all replacement electrical components comply with the original parts and are correctly adjusted.
- All other repairs must be completed by competent, qualified personnel.
- Make certain that process materials and replaced parts are disposed of safely and in an environmentally-appropriate manner.
- **FAILURE TO REPLACE LOOSE OR DAMAGED PARTS COULD CAUSE DAMAGE TO THE EQUIPMENT AND/OR SERIOUS INJURY OR DEATH TO THE OPERATOR!**
- Verify that aggressive cleaning products are not used.
- **MAKE CERTAIN TO NEVER WELD, FLAME CUT/TORCH, OR PERFORM ANY GRINDINGWORK ON THE BP-15 SUPER WITHOUT WRITTEN AUTHORIZATION FROM BLASTPRO MANUFACTURING, INC!**
- Make certain that electrical equipment is inspected regularly.
- Verify that all screw connections that were undone during maintenance work are retightened prior to putting the machine back into operation.
- After performing maintenance operations on the BP-15 SUPER and dust collector, verify that all safety labels, guards, control panels, housings, lids, seals, casters, magnets and other parts that have been replaced are secure.

## Operating Instructions

1. Verify that competent personnel have read and understand the safety information in this manual and are following all safety instructions and programs required by their company and the worksite. Verify that the BP-15 SUPER is on a level, clean, debris-free and dry surface.
2. Connect hose from 9-54 to BP-15 SUPER. Verify clamps are secure. Verify that the BP-15 SUPER is on a level, clean, debris-free and dry surface.
3. Verify dust bin in dust collector is empty and hose is free of debris.
4. Verify the switch on the control panel on the BP-15 SUPER is set to the OFF position.
5. Verify the switch on the control panel on the 9-54 is set to the OFF position.
6. Insert cord from 9-54 into a 240 or 480 volt electrical outlet after confirming proper voltage with a voltmeter.
7. Any hardwiring or circuit breaker changes should be performed by a licensed electrician.
8. Before loading shot into machine turn the switch on the BP-15 SUPER and the 9-54 to the ON position to verify circuit breaker will not trip.
9. Disconnect hose from the BP-15 SUPER to verify dust collector has proper suction.
10. After verifying proper suction reconnect hose to the BP-15 SUPER.
11. Check seals on BP-15 SUPER to verify seals are set at the proper height. The seals should be rubbing the surface of the concrete or steel.
12. Place a handful of steel shot in front of BP-15 SUPER.
13. Drive BP-15 SUPER over the handful of steel shot. This will attach the steel shot to the magnetic seals and prevent shot from escaping from BP-15 SUPER.
14. Pour steel shot into BP-15 SUPER shot hopper to the bottom of the screen.
15. Turn switch on BP-15 SUPER to the ON position, push handle to open shot valve. Verify blast pattern is uniform. If blast pattern is not uniform, close handle to close shot valve, and turn switch on BP-15 SUPER to the OFF position and go to 17. below.
16. Adjust the control cage.
17. Turn switch on BP-15 SUPER to ON position, push handle to open shot valve, and verify blast pattern is uniform.
18. Once blast pattern is uniform start shotblasting.

## Setting the Blast Pattern

Setting the proper blast pattern is determined by trial and error. The importance of selecting the proper blast pattern cannot be overstated. An improper or unevenly distributed blast pattern will result in excessive blasting on either the right side or left side of the machine and will leave shadows or “track” lines in the blast pattern.

1. Verify that the blast wheel is rotating in the direction shown on the blast housing.
2. Place a sheet of steel approximately ¼” thick under the machine and then blast with the shot valve fully open for approximately sixty seconds.  
**Note: Do not move the machine during this time.**
3. After blasting for 60 seconds, shut down the machine and inspect the blast pattern. The “hot spot” should be in the center of the width blasted. The “hot spot” can be altered by rotating the control cage in small increments. Rotating the control cage in a counter-

clockwise direction will move the “hot spot” to the right while rotating the control cage in a clockwise direction will move the “hot spot” to the left. If you visualize a clock, the opening of the control cage should be set at approximately 10:30 (leading edge) and 8:30 (trailing edge) on the clock (see Proper Control Cage Setting Drawing below). The size of steel shot used will impact where the “hot spot” appears in the blast pattern. The operator will need to adjust the control cage based upon the size of steel shot utilized.

**Note: The setting of the control cage will vary depending both on the size of shot used and on the type of surface being blasted. When altering the position of the control cage, make sure to only adjust it in small increments. Keep adjusting the control cage until the desired blast pattern has been obtained. Once the desired blast pattern has been obtained, the blast pattern should remain consistent.**

**Note: Four factors may affect the blast pattern. Of these, the control cage setting is the most crucial. Other factors that may also affect the blast pattern include the size of the shot being used, the wheel rotation, and the worn wheel kits. If adjusting the control cage setting does not allow the desired blast pattern to be achieved, then it is important to narrow down what is causing the problem. First, take into consideration the size of shot being used. If this does not resolve the problem, then check and, if necessary, replace the wheel rotation and the worn wheel kits.**

**Proper Control Cage Setting Drawing**

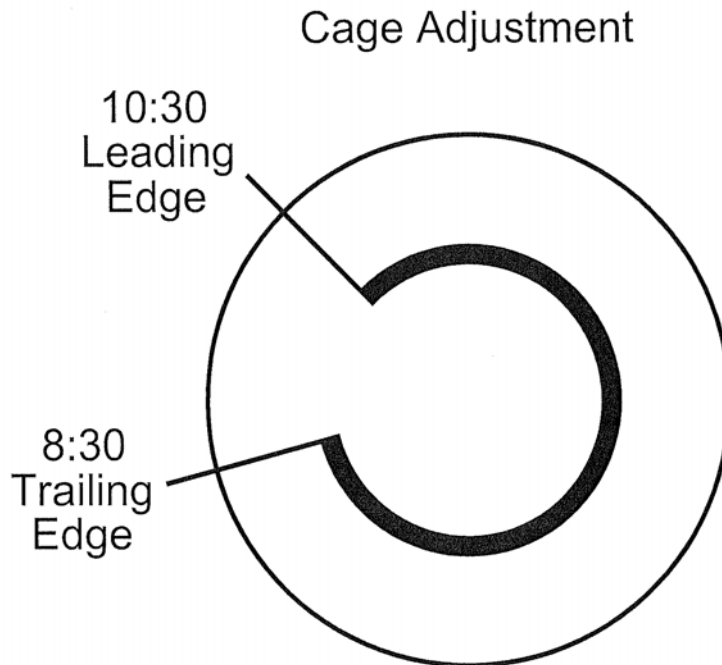

## Transportation

When transporting the BP-15 SUPER shotblasting machine, it is strongly recommended that personnel act in a manner so as to reduce the potential that damage takes place as a result of using excessive force or of using incorrect loading and unloading procedures.

**Note: Personnel must remove any shot from the machine before it is transported. Also, the machine may only be lifted by using the suspension eyelets; forklifts should never be used to transport the BP-15 SUPER shotblasting machine.**

## Wear Parts

The BP-15 SUPER contains parts which are continually exposed to steel shot moving at high rates of speed. Exposure to steel shot traveling at high rates of speed and concrete dust causes these parts to deteriorate. As a result, the operator or maintenance personnel should inspect the BP-15 SUPER wear parts prior to operation and change the parts as necessary. Wear parts and inspection times, other than inspection prior to use, on the BP-15 SUPER are listed below:

<b>Part</b>	<b>When to Inspect</b>	<b>Evidence of Wear</b>
Shot Hopper	30 hours	Warping or thin spots
Feed Spout	50 hours	Thin spots
Blast Wheel	10 hours	Blades deteriorated > 50%
Control Cage	10 hours	Deteriorated edges
Blast Wheel Hub	10 hours	Missing pins/deterioration
Liners	10 hours	Warping, holes, deterioration
Blast Housing	50 hours	Thin sections or other deteriorations

**Note:** Parts of the BP-15 SUPER which should also be inspected regularly but are not exposed to steel shot are the control panel, motor, electric cords, dust collector hose, filters, and motors. If any of these components show signs of wear they should be repaired so that they are in the same working condition as when they were new. If they cannot be repaired, then they should be replaced immediately.



## Maintenance

### Blast Wheel Removal and Installation

When the blades on the blast wheel are deteriorated by 50% or more, then the blast wheel should be replaced. To replace the blast wheel, perform the following steps:

1. Verify that the control switch is in the OFF position.
2. Verify that the power cord is NOT plugged into an electrical outlet.
3. Verify that the shot valve is closed.
4. Loosen all nuts and clamps that secure the feed spout and the control cage.
5. Remove the feed spout.
6. Remove the control cage.
7. Mark plate with ink pen where control cage openings appear to aid in realignment.
8. Remove the four sets of nuts and washers securing the control cage assembly to the housing.
9. Remove the control cage assembly.
10. Remove the arbor nut and the blast wheel.
11. Check the wheel hub for wear and replace when necessary.
12. Install the new blast wheel and the arbor nut.
13. Reattach the control cage assembly that was previously removed.
14. Insert the new control cage that was provided with the blast wheel kit. Spin the blast wheel by hand to verify that the blast wheel and the control cage do not come into contact with one another. Openings of control cage should be set at approximately 10:30 (leading edge) and 8:30 (trailing edge).
15. Reattach the feed spout
16. Verify that all nuts are tight and secure
17. Briefly activate the grinder motor to verify good balance and proper clearance.

**Note: Only blast wheels manufactured by BlastPro Manufacturing, Inc. should be used by the BP-15 SUPER. Other blast wheels that have not been tested by BlastPro Manufacturing, Inc. could result in damage to the equipment or injury to the operator.**

## General Maintenance Points

Below is a matrix of general maintenance points and intervals. These intervals are general recommendations based on normal operation. These intervals should be adjusted during use in extreme conditions or extended periods of used.

MAINTENANCE POINT	INTERVAL
INSPECT SEALS	DAILY
INPECT LINERS	DAILY
INSPECT WHEEL KIT	DAILY
INSPECT POWER CHORD	DAILY
INSPECT DUST HOSE	DAILY
CHECK/ADJUST BELT TENSION	EVERY 4-6 HOURS
GREASE BEARING UNIT	EVERY 50 HOURS

### Greasing the Bearing Unit

The bearing unit is located on the back of the blast housing. The unit must receive regular lubrication to operate properly. Blastpro Manufacturing recommends using Mobil Polyrex EM grease.

There are grease fittings at both ends of the bearing unit. Each fitting should receive several pumps of grease. Once the unit is greased, run the unit without blasting for 10-15 minutes. This will help distribute the grease evenly. **Care should be taken not to over-grease the unit.**

### Checking Belt Tension

Correct blast wheel belt tension is required to maximize efficiency and prolong the life of the belts, bearing unit and sheaves. If the belt does not have enough tension there will not be proper power transmission from the motor to the blast wheel. An overly tight, or loose, condition can lead to accelerated belt wear.

When checking the belt tension, the belt should deflect 1/64” per inch of center-to-center distance between the sheaves. The optimal force for testing the belt is 11 lbs (min 9, max 13).

When possible, the use of a belt tension tester is recommended.

## PARTS LISTS

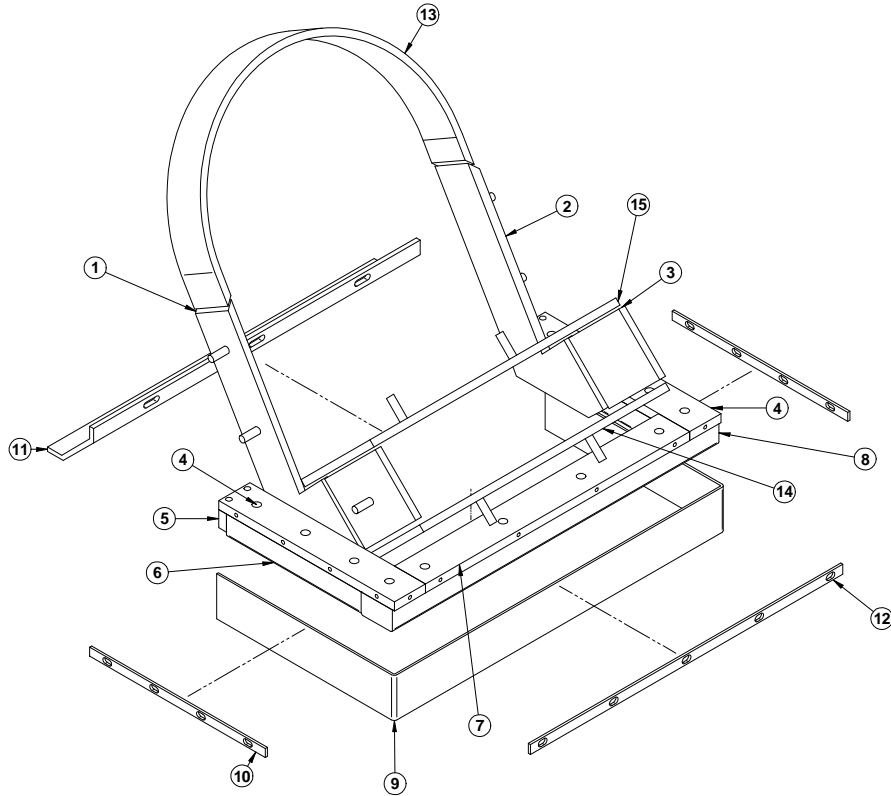

## LINERS AND SEALS

ITEM NUMBER	QUANTITY	PART NUMBER	DESCRIPTION
1	1	BT4899470_	LEFT LINER 10D
2	1	BT4899480	RIGHT LINER 10D
3	2	BT4900450_	SIDE REBOUND 10D
4	2	BT4899450	INSULATOR/MAGNET SIDE
5	1	BT4813500	SPACER/INSULATOR
6	2	BT4900470_	SIDE MAGNET
7	1	BT4990900_	INSULATOR/MAGNET FRONT
8	1	BT4990970_	FRONT MAGNET
9	1	BT4991020	MAGNET SEAL BP-15
10	2	BT4900510_	SIDE RETAINER
11	1	BT6826520-SKID	SKID SEAL
12	1	BT4991010_	RETAINER/FRONT MAGNET SEAL
13	1	BT4990910_	TOP LINER
14	1	BT4990920	BOTTOM REBOUND LINER
15	1	BT4990930_	UPPER REBOUND LINER

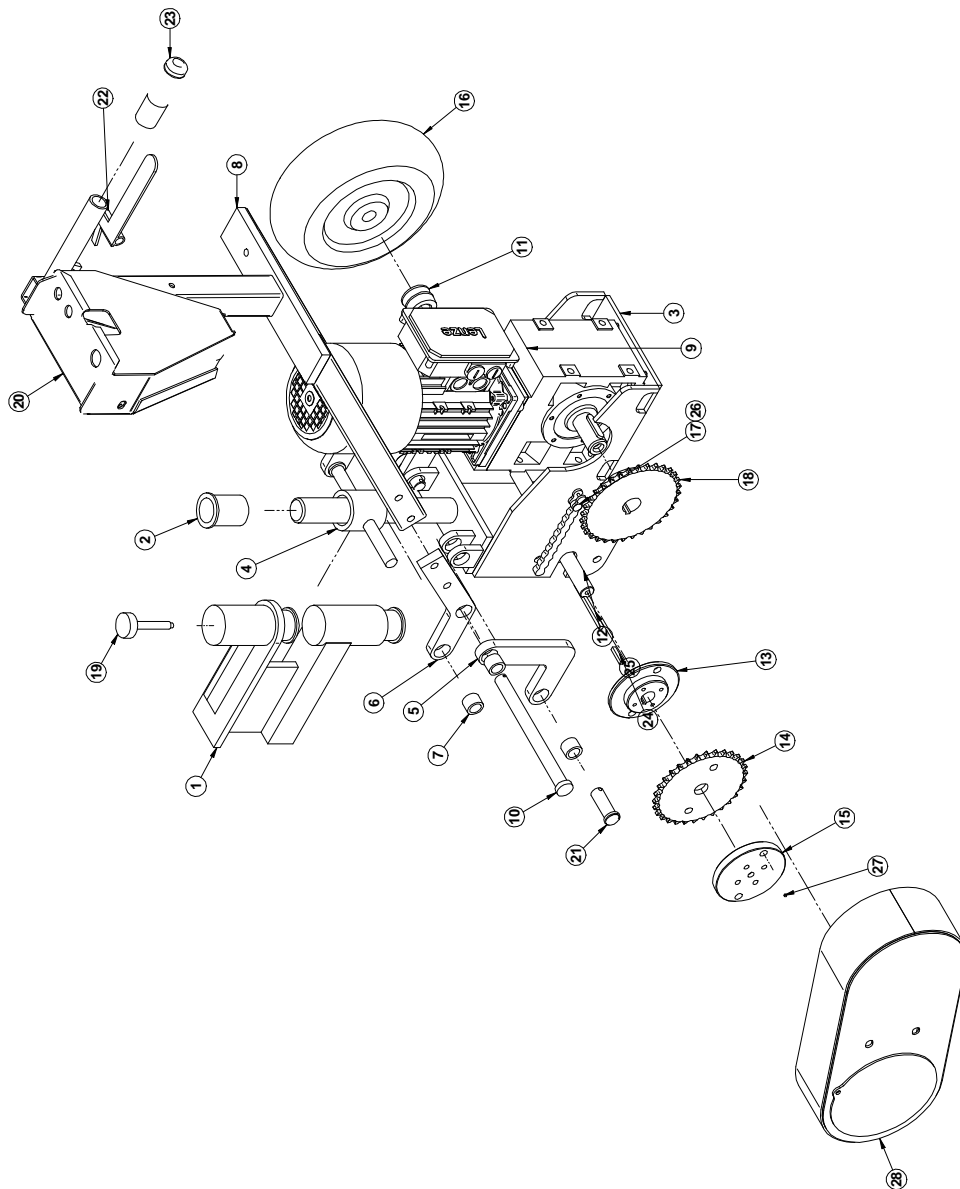

**FRONT END ASSEMBLY**

ITEM NUMBER	QUANTITY	PART NUMBER	DESCRIPTION
1	1	BT6760380_A	REBOUND PLENUM
2	3	BT4918480	2" RULON BUSHING FLANGED
3	1	BT4900780-AC DRIVE	SUPPORT DRIVE YOKE/AC DRIVE
4	1	BT4919500	YOKE
5	2	BT4919480_	LINKAGE FRONT END ASSEMBLY
6	2	BT4919490_	ARM/LINKAGE
7	4	BT4918460	RULON BUSHING
8	1	BT4900760-AC	DRIVE HANDLE
9	1	BT4835160-AC	GEARBOX - AC DRIVE
10	1	BT4919690	PIN/CLEVIS
11	2	BT2055710	3/4" 2 BOLT FLG BEARING 1-10D
12	1	BT4900720-AC	SHAFT/FRONT WHEEL
13	1	BT4776290	HUB TRACTION DRIVE
14	1	BT4776310	SPRKT/40-1 30T 1-10D
15	1	BT4776300	RETAINER/SPROCKET
16	1	BT4900790	DRIVE TIRE
17	1	BT4920110	CHAIN ASA #40
18	1	BT0842340-1	SPROCKET/40-1-32T
19	1	BT6729460	SWIVEL SCREW
20	1	BTP003005	POT POD
21	2	BT4919680	CLEVIS PIN
22	1	BT4900740_	LEVER FOR HANDLE
23	1	BT4532900	GRIP/ HANDLE 1.00" ID RUBBER
24	1	BT5019020_	KEY 3/16 X 3/16 X 1
25	1	BT5019070_	KEY 3/16 X 3/16 X 3
26	1	BT4528360	LINK
27	1	BT4781980	PIN
28	1	BT4900770-AC	CHAIN GUARD BP-10 AC DR

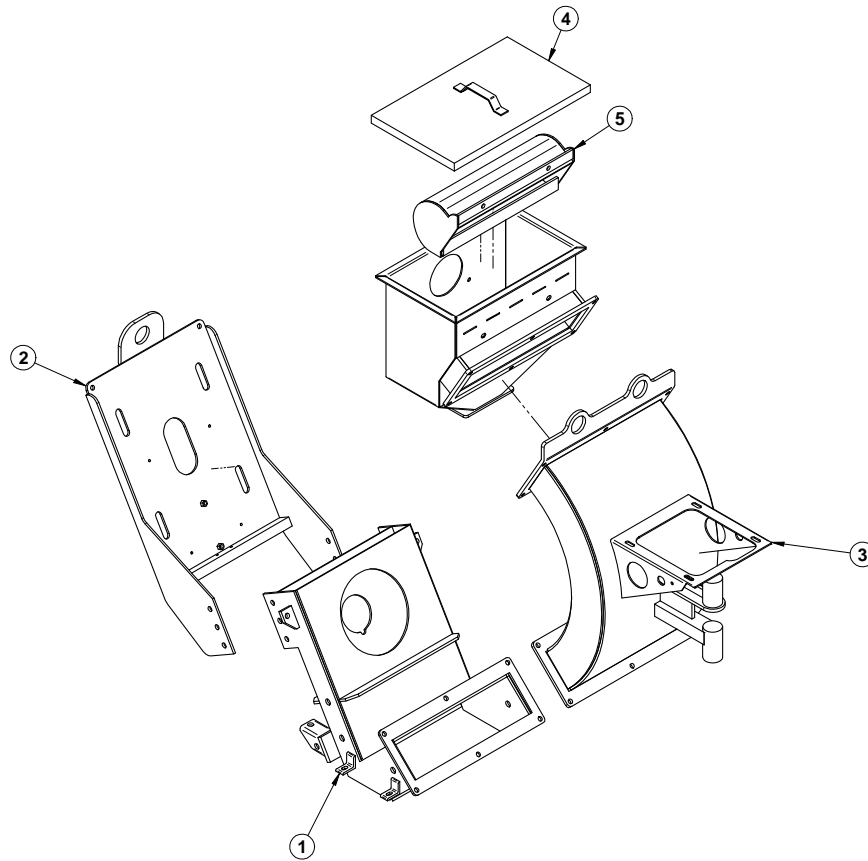

**MAJOR WELDMENTS**

ITEM NUMBER	QUANTITY	PART NUMBER	DESCRIPTION
1	1	BT6761700	HOUSING
2	1	BT6769980_	MOTOR BRACKET
3	1	BT6760380_A	REBOUND PLENUM
4	1	BT6762370	SEPARATOR ASSEMBLY
5	1	BT6762510_1	HALF PIPE DEFELCTOR/SEPARATOR

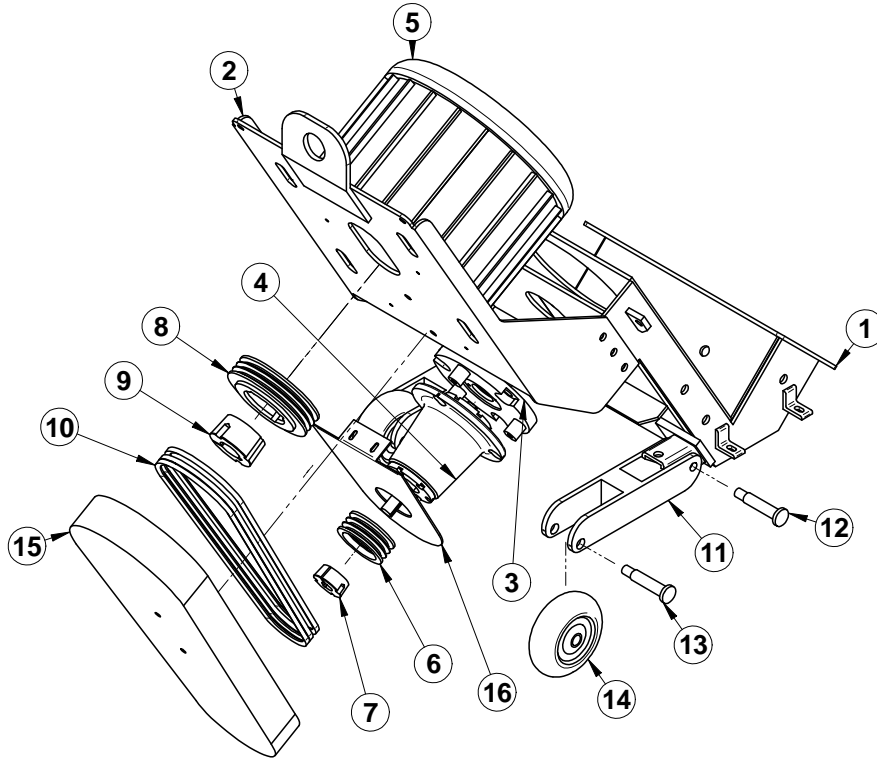

### **BACK END ASSEMBLY**

ITEM NUMBER	QUANTITY	PART NUMBER	DESCRIPTION
1	1	BT6761700	HOUSING
2	1	BT6769980_	MOTOR BRACKET
3	1	BT4959430	MOUNT BEARING UNIT
4	1	BT4892950	BEARING UNIT
5	1	BT6976390	20 HP MOTOR
6	1	BT6997040	3V 3GR 3.65" PULLEY
7	1	BT6997040-1	1610 T/L BUSHING
8	1	BT6997050	3V 3GR 6.50 SHEAVE
9	1	BT6997050-1	TAPER LOCK BUSHING
10	3	BT6997060	3VX BELT
11	2	BT6762470	IDLER BRACKET
12	1	BT6762790-1	SHOULDER BOLT 1-15D FRONT
13	1	BT6762790	SHOULDER BOLT 1-15D BACK
14	2	BT6785870	IDLER WHEEL
15	1	BT6997030_	BELT GUARD BLAST MOTOR
16	1	BT4917410-1	BACK PLATE DRIVE GUARD

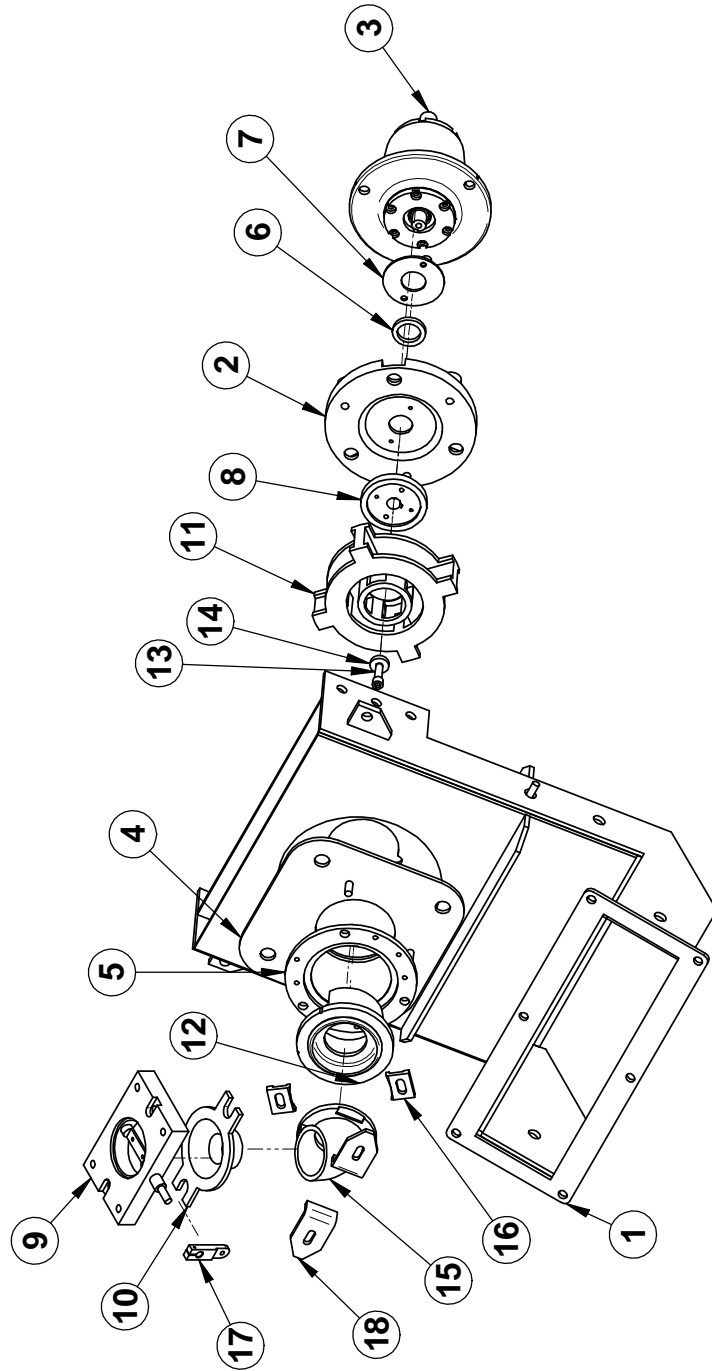

**BLAST WHEEL ASSEMBLY**



ITEM NUMBER	QUANTITY	PART NUMBER	DESCRIPTION
1	1	BT6761700	HOUSING
2	1	BT4959430	MOUNT BEARING UNIT
3	1	BT4892950	BEARING UNIT
4	1	BT4959410	CONTROL CAGE BRACKET
5	1	BT4959420	SUPPORT/BRKT CONTROL CAGE
6	1	BT4959380	FELT SEAL BEARING UNIT
7	1	BT4959370_	RETAINER FELT SEAL BEARING UNIT
8	1	BT4959400_A	BLAST WHEEL HUB
9	1	BT6800200_	SHOT VALVE
10	1	BT4936980	ADAPTER/FEED SPOUT
11	1	BT4937000	FEED SPOUT
12	1	BP4936990	CONTROL CAGE BP-10
13	1	BT5004650	BLAST WHEEL BOLT
14	1	NUTS & BOLTS-101	SPHERICAL WASHER ASSY
15	1	BP4937010	8" BLAST WHEEL BP-10-15
16	2	BT4146990	CLAMP/CONTROL CAGE
17	1	BT4784610_	SHOT VALVE LINKAGE
18	2	BP4939650	FEED SPOUT CLAMP-BP

**NOTE: Items 12, 13, 14 and 15 are included in part number BT6774960\_. Use this number when ordering replacement wheel kits.**

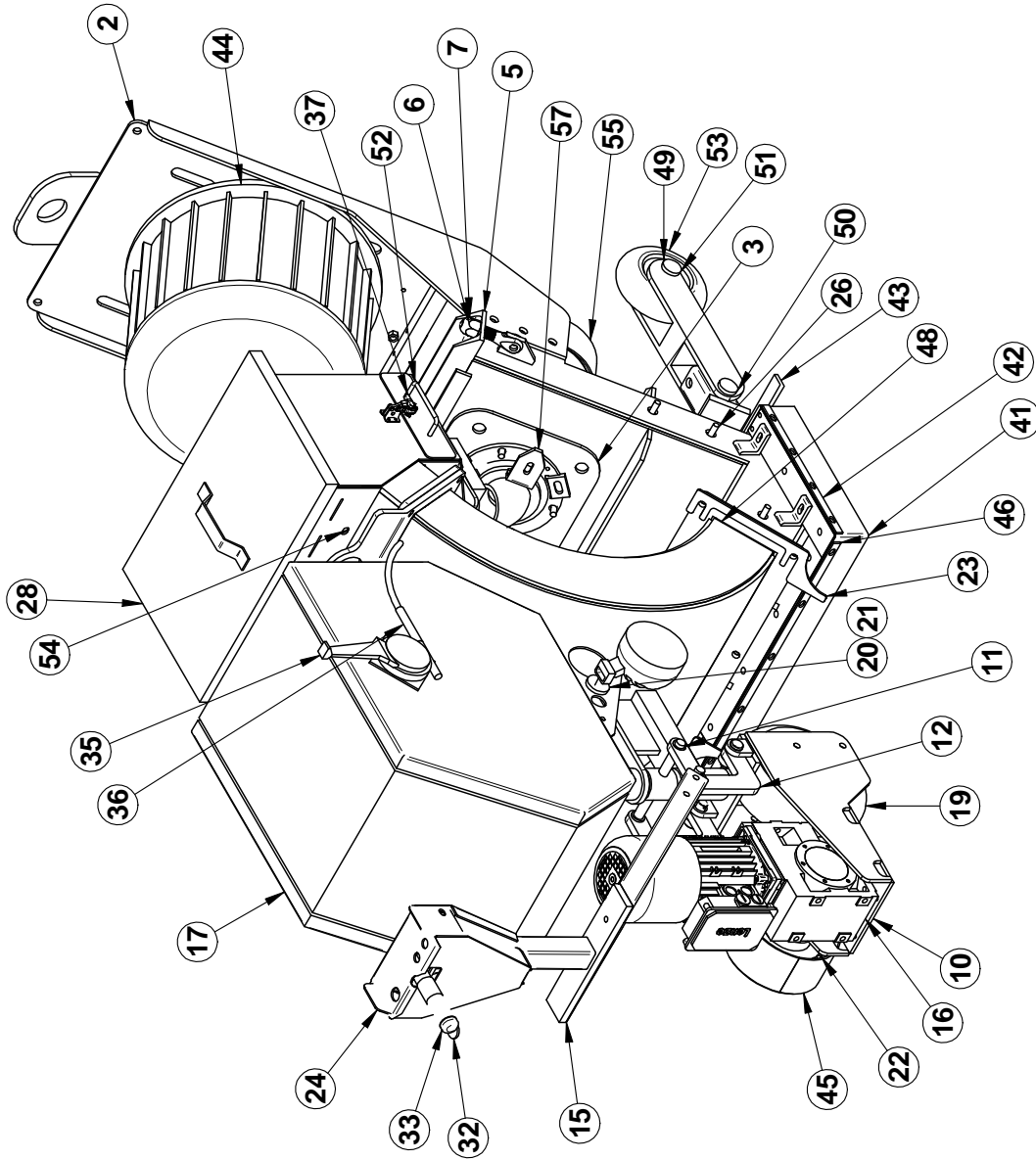

**GENERAL ASSEMBLY**

ITEM NUMBER	QUANTITY	PART NUMBER	DESCRIPTION	ITEM NUMBER	QUANTITY	PART NUMBER	DESCRIPTION
1*	1	BT6761700	HOUSING	40*	1	BT4990900_	INSULATOR/MAGNET FRONT
2	1	BT6769980_	MOTOR BRACKET	41	1	BT4991020	MAGNET SEAL BP-15
3	1	BT4959410	CONTROL CAGE BRACKET	42	1	BT4900510_	SIDE RETAINER
4*	1	BT4959420	SUPPORT/BRKT CONTROL CAGE	43	1	BT6826520-SK ID	SKID SEAL
5	1	BT4990880	BLAST HOUSING COVER	44	1	BT6976390	20 HP MOTOR
6	1	BT2365910	BOLT/JAW 1/2 X 13X6.5	45	1	BT4900770-AC	CHAIN GUARD BP-10 AC DR
7	1	BT1984570	1/2X13 CAP NUT HARD	46	1	BT4991010_	RETAINER/FRONT MAGNET SEAL
8*	1	BT6760380_A	REBOUND PLENUM	47*	1	BT4990920	BOTTOM REBOUND LINER
9*	2	BT4918480	2" RULON BUSHING FLANGED	48	1	BT4990930_	UPPER REBOUND LINER
10	1	BT4900780-AC DRIVE	SUPPORT DRIVE YOKE/AC DRIVE	49	1	BT6762470	IDLER BRACKET
11	1	BT4919500	YOKE	50	1	BT6762790-1	SHOULDER BOLT 1-15D FRONT
12	2	BT4919480_	LINKAGE FRONT END ASSEMBLY	51	1	BT6762790	SHOULDER BOLT 1-15D BACK
13*	2	BT4919490_	ARM/LINKAGE	52	1	BT4895410-1	SHOT SCREEN HANDLE
14*	5	BT4918460	RULON BUSHING	53	1	BT6785870	IDLER WHEEL
15	1	BT4900760-AC	DRIVE HANDLE	54	1	BT6762510_1	HALF PIPE DEFELCTOR/SEPARATOR
16	1	BT4835160-AC	GEARBOX - AC DRIVE	55	1	BT6997030_	BELT GUARD BLAST MOTOR
17	1	BTP000189/AC DRIVE	ELECTRICAL BOX/AC DRIVE	56*	1	BT4917410-1	BACK PLATE DRIVE GUARD
18*	1	BT4919690	PIN/CLEVIS	57	2	BP4939650	FEED SPOUT CLAMP-BP
19	1	BT4900790	DRIVE TIRE				
20	1	BP505-0010	WORK LIGHT MAGNET				
21	1	BP505-0001	12V LED LIGHT				
22	1	BT0842340-1	SPROCKET/40-1-32T				
23	2	BTP003047	BLAST PATTERN INDICATOR				
24	1	BTP003005	POT POD				
25*	2	BT4919680	CLEVIS PIN				
26	1	BT4899480	RIGHT LINER 10D				
27*	1	BT4900450_	SIDE REBOUND 10D				
28	1	BT6762370	SEPARATOR ASSEMBLY				
29*	1	BT6800200_	SHOT VALVE				
30*	1	BT4936980	ADAPTER/FEED SPOUT				
31*	1	BP4936990	CONTROL CAGE BP-10				
32	1	BT4900740_	LEVER FOR HANDLE				
33	1	BT4532900	GRIP/ HANDLE 1.00" ID RUBBER				
34*	1	BT4937000	FEED SPOUT				
35	1	BTP000735	OPERATOR HANDLE				
36	1	BTP000737	CABLE/SHOT VALVE				
37	1	BT03600001	TOGGLE CLAMP				
38*	1	BT4146990	CLAMP/CONTROL CAGE				
39*	2	BT4899450	INSULATOR/MAGNET SIDE				

# Installation Instructions for D65 Series Phase Monitoring Relay



IL04914001E

## Installation Instructions for D65 Series Phase Monitoring Relay

READ INSTRUCTIONS BEFORE INSTALLING OR OPERATING THIS DEVICE. KEEP FOR FUTURE REFERENCE.

### WARNING

Potentially hazardous voltages are present. Turn off all power supplying this equipment before connecting or disconnecting wiring.

Table 1. Protection Provided

Product	Phase Reversal	Phase Loss	Undervoltage (75-95%)
D65VMC	X		
D65PLR	X	X	
D65PAR	X	X	X

### Installation and Setup

**NOTE:** The Line Voltage connected to Pins 3, 4 & 5 must not exceed 110% of the Nominal Voltage rating on the product nameplate (**NOTE:** for the D65VMC480 product, the voltage must not exceed 110% of 480V AC, or 528V AC).

1. Mount an appropriate 8 pin 600V octal socket (Eaton Catalog Number D3PA2).
2. (D65PAR only) Set UNDERVOLTAGE dial to 75% (minimum). **NOTE:** when setting the undervoltage value, use the appropriate dial indicator: Solid Line for 60 Hz; Dashed Line for 50 Hz (see Figure 1).
3. Connect the 3-phase line voltage to terminals 3, 4 & 5 (see Wiring Diagram on back). **DO NOT** connect output terminal wires until later (Step 6). Plug the unit into the socket.

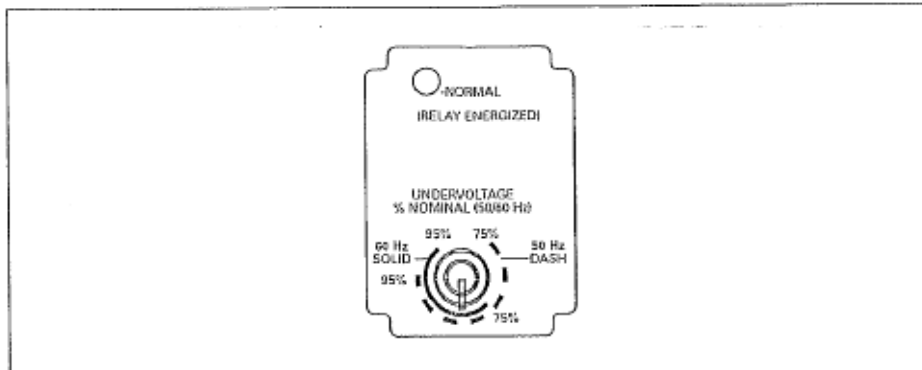

Figure 1. Undervoltage Dial

4. Apply Line Voltage. The LED indicator should illuminate RED. If not, a fault condition exists and must be corrected. Check to see if all phases are present. REMOVE LINE VOLTAGE, and switch any two of the line voltage connections to insure the phase rotation is correct. Reapply line voltage to check for correct phase rotation. (D65PAR only) Check to see if line voltage is at least 75% of the nominal voltage.
5. (D65PAR only) Set the UNDERVOLTAGE dial. This setting should be the same as the minimum operating voltage for the equipment to be adequately protected.
6. Connect the output terminal wires.
7. Apply Line Voltage. The LED indicator will illuminate RED, the internal relay will energize, and the 3-phase system will become operational.
8. If the LED does not illuminate RED during regular operation, a fault condition has occurred. REMOVE LINE VOLTAGE, and check for proper phase rotation, presence of all three phases, and (D65PAR only) low voltage conditions. Correct if necessary. Re-energization is automatic upon correction of the fault condition.

### Troubleshooting

If the unit fails to operate properly, check that all connections are correct per the appropriate wiring diagram. If problems continue, contact EATON TRC 1-800-809-2772 for assistance.

### Wiring Diagrams/Typical Connections

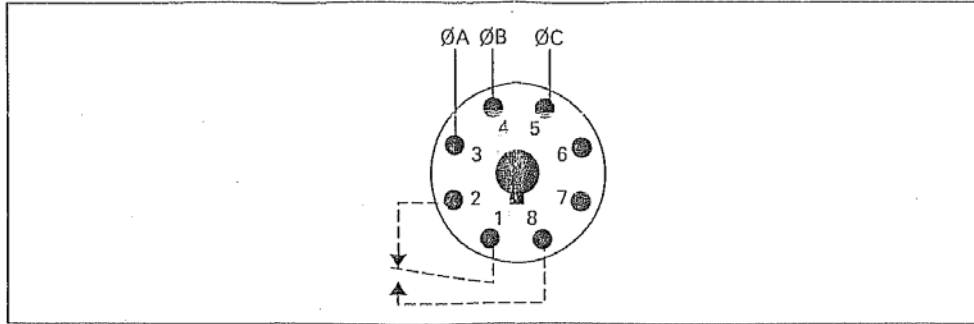

Figure 2. Wiring Diagram

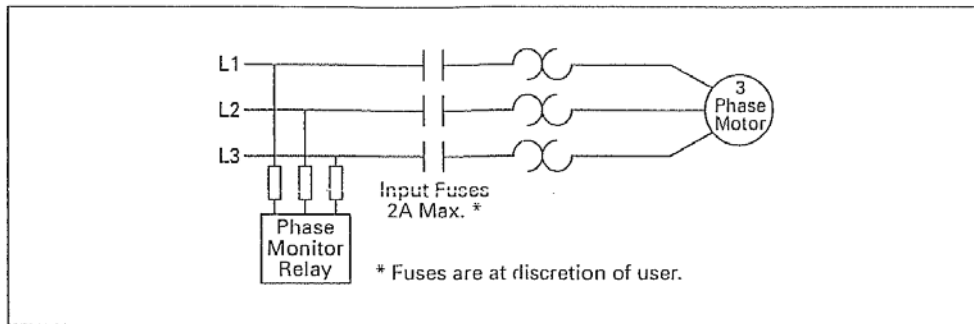

Figure 3. Typical Connections

## Shotblasting Problems & Possible Solutions

**Problem:** Breaker is tripping when BP-15 SUPER and dust collector are turned to the ON position.

**Possible Solution:** BP-15 SUPER and dust collector should be powered by separate breakers. Find electric outlets with separate breaker switches and use accordingly. Check circuit breaker sizes.

**Problem:** BP-15 SUPER is vibrating excessively.

**Possible Solution:** Check blast wheel immediately. Excessive vibration is usually caused by the blast wheel being out of balance due to it being worn or by blades being broken or chipped. Install new blast wheel kit. Failure to install new wheel kit in this instance could lead to serious damage to machine.

**Problem:** BP-15 SUPER is creating excessive noise.

**Possible Solution:** This problem is most likely caused by an improper alignment of the blast wheel and control cage. Check alignment of blast wheel and control cage immediately and verify that there is adequate clearance between the blast wheel and the control cage.

**Problem:** BP-15 SUPER is creating excessive wear on liners and blast housing.

**Possible Solution:** Adjust control cage so that the “hot spot” is centered in work area rather than on liners or housing.

**Problem:** BP-15 SUPER is dropping an excessive amount of steel shot.

**Possible Solution:** Verify “hot spot” is centered properly and adjust control cage as necessary. Verify seals do not have excessive wear, feed spout is aligned properly, and shot valve is closing when shot lever is released. Verify dust collector has adequate suction.

**Problem:** The blasting performance of the BP-15 SUPER has diminished.

**Possible Solution:** Verify that there is an adequate amount of steel shot in the shot hopper and that shot is free of concrete dust or other contaminants. Verify there are no obstructions in the shot valve or feed spout and the feed spout is properly aligned. Verify that the shot valve is opening properly. Verify that the blast wheel and the control cage are not excessively worn. Verify dust collector has adequate suction.

**Problem:** BP-15 SUPER is difficult to push or gets stuck in areas.

**Possible Solution:** Verify that the seals are positioned properly and that they are not too close to the floor. Raise height of seals.

**Problem:** The steel shot in the shot hopper contains an excessive amount of concrete dust.

**Possible Solution:** Verify that the vacuum has good suction. If this does not resolve problem, then increase the travel speed of the BP-15 SUPER to reduce amount of concrete being removed. If this does not produce an adequate profile, then make additional passes over the floor surface.

**Problem:** BP-15 SUPER or dust collector is emitting concrete dust.

**Possible Solution:** Verify there are no holes in the duct hose leading from the BP-15 SUPER to the dust collector. Verify filters in the dust collector are properly installed and are clean. If necessary replace filters in dust collector.

**Problem:** Steel shot is being sucked into dust bin.

**Possible Solution:** Dust collector is producing too much suction for the size of shot being used. Restrict air flow on dust collector. To do this, open one or both dampeners on the dust collector housing.